



BTPX 305

Pilot plant separation system



Typical example of a BTPX 305 separation system for steam sterilization and contained operation.

The key to success in bridging the gap from the laboratory to commercial production is a pilot plant that delivers results that will be relevant when you move into full-scale production. Scaling-up involves compromises that often cannot be predicted in the laboratory. Alfa Laval solves this problem with the versatile BTPX 305 centrifuge. Suitable for feedrates up to 2 000 litres per hour, the BTPX 305 can be delivered in a multitude of configurations and it is therefore adaptable to almost any duty and application imaginable.

For hazardous duties the centrifuge complies with ATEX requirements for zone 1 or 2 and a skid mounted separation system can be designed for inert gas purging, thus insuring the highest level of safety.

For biological hazards the separation system can be designed for steam sterilization and contained operation, which meets the requirements of the NIH guidelines for BLS 2. Furthermore, Alfa Laval's experience in hygienic equipment design and GMP manufacturing ensure the integrity of valuable biopharmaceuticals.

Applications

The BTPX 305 is a solids-ejecting centrifuge in clarifier, purifier and concentrator execution, equipped with a well-proven, reliable fixed partial solids discharge, which can be initiated by timer, turbidity and/or totalised flowrate. In the clarifier execution the centrifuge is used for removing suspended solids from a liquid, while in the purifier and concentrator execution it is used for removing suspended solids, while separating two intermixed and immiscible liquid phases of different densities. The solids content in the feed is normally in the range of 0.1 – 10% by volume, but can vary between different duties.

Complete separation systems

Alfa Laval has over a hundred years experience in the design and supply of separation equipment. Complete systems, customized for specific applications, can be provided in a compact, fully tested, skid-mounted assembly. For process flow equipment, such as valves and instruments as well as control systems, Alfa Laval use only leading subsuppliers. Many options are available and we are willing to discuss specific requirements.

Standard centrifuge design

The centrifuge consists of a frame that has a horizontal drive shaft, worm gear, lubricating oil bath and vertical bowl spindle in the lower part. The bowl is mounted on top of the spindle, inside the space formed by the upper part of the frame, the ring solids cover, the collecting cover, and the frame hood. The liquid discharge system also rests on this structure. All parts in contact with the process liquid are made of stainless steel. The bowl is of the solids-ejecting disc type with an automatic hydraulic operating system for discharging. It is a so called timer triggered partial discharge system, meaning that only part of the bowl content is emptied during pre set discharge intervals. The discharge takes place at full speed without any interruption of the feed. The centrifuge is equipped with nozzles for flushing of the bowl top and the sediment outlet.

The centrifuge is available with main connections and all utility connections as sanitary clamp type. The electric motor is of integral type with a frequency converter integrated in the motor.

Basic executions

BTPX 305SGD-34CDEP Clarifier. Suspended solids are removed from a liquid

BTPX 305TGD-14/74CDEP Purifier/Concentrator. Suspended solids are removed, while separating two intermixed liquid phases.

Available models

The BTPX 305 centrifuge is available in different surface finish executions:

Bowl spindle	Ra 0.8. Ra 0,5 and electro polished.
Machine top part	Inside Ra 1.2. Outlet cover Ra 0.5 and electro polished.
Machine top part	Inside Ra 0.8. Outlet cover Ra 0.8.
Machine top part	Inside Ra 0.8. Outlet cover Ra 1.2.
Separator bowl	Inside 0.5 Ra and electro polished. Outside 0.8 Ra.
Separator bowl	Inside 0.8 Ra, outside 0.8 Ra.
Separator bowl	Inside 1.2 Ra, outside 1.2 Ra.



BTPX 305 solids-ejecting disc stack centrifuge

Material data

Bowl body, hood and lock ring	Stainless steel 1.4462 UNS S31803
Solids cover and frame hood	Stainless steel ASME SA-240 S31603
Cyclone	Stainless steel ASME SA-240 S31603
Bottom frame	Cast grey iron
Inlet and outlet	Stainless steel, mostly 1.4401 UNS 31600
Gaskets and O-rings	EPDM rubber (FDA approved food grade), viton or nitrile

Working principles (clarifier execution)

The feed is introduced to the rotating centrifuge bowl (fig 1) from the top via a stationary inlet pipe (1), and is accelerated in a distributor (2) before entering the disc stack (3). It is between the discs that the separation of the liquid phase and the solids phase takes place.

The liquid phase moves towards the centre of the bowl from where it is pumped out under pressure by means of a built-in paring disc (4).

The heavier solids phase is collected at the bowl periphery, from where it is discharged intermittently via the centrifuge cyclone. The solids discharge is achieved by a hydraulic system below the separation space in the bowl, which at preset intervals forces the sliding bowl bottom (5) to drop down, thus opening the solids ports (6) at the bowl periphery. The high velocity of the ejected solids is reduced in the cyclone.

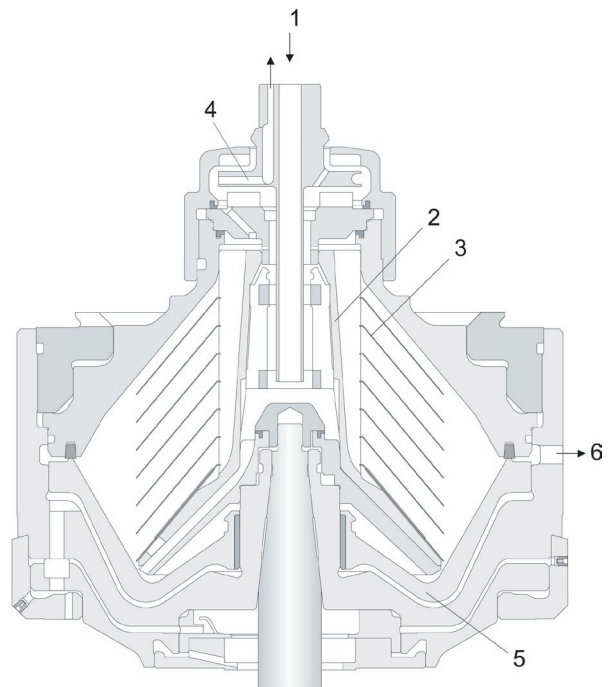
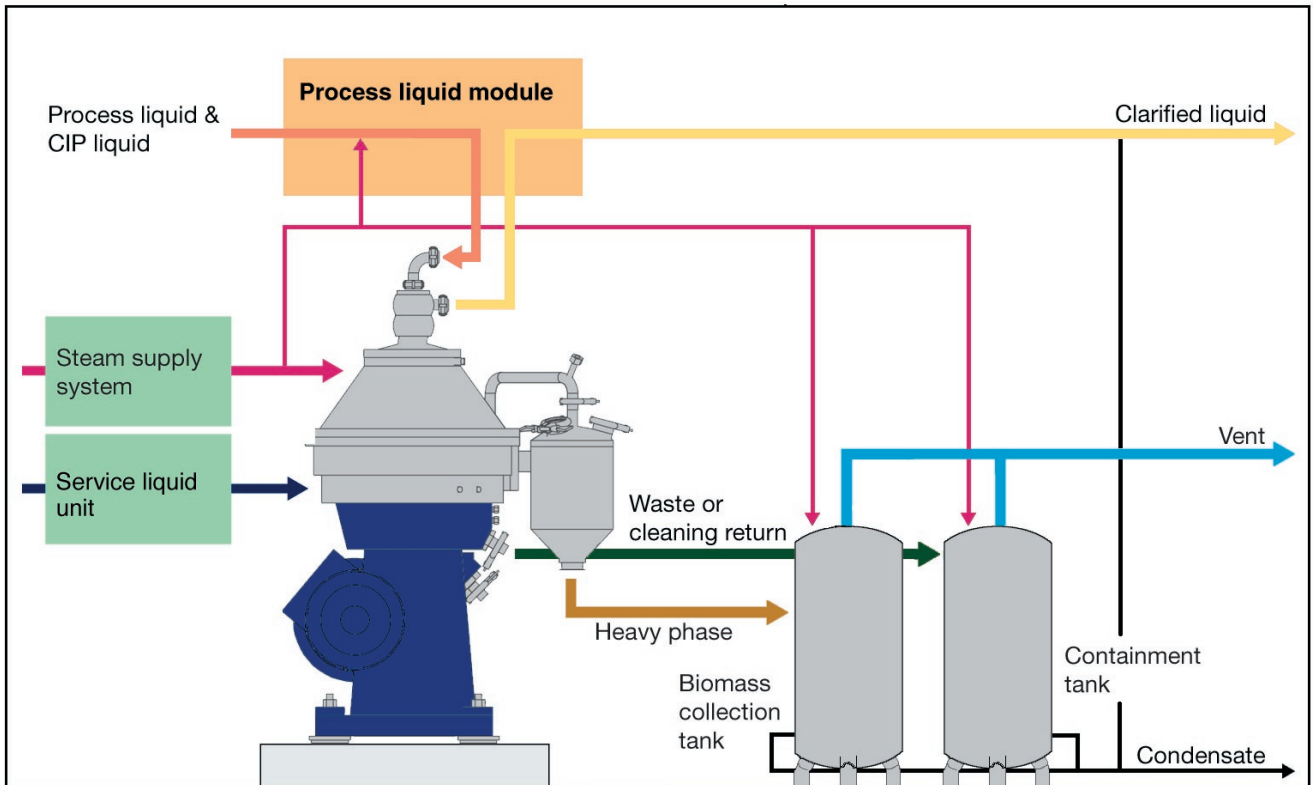
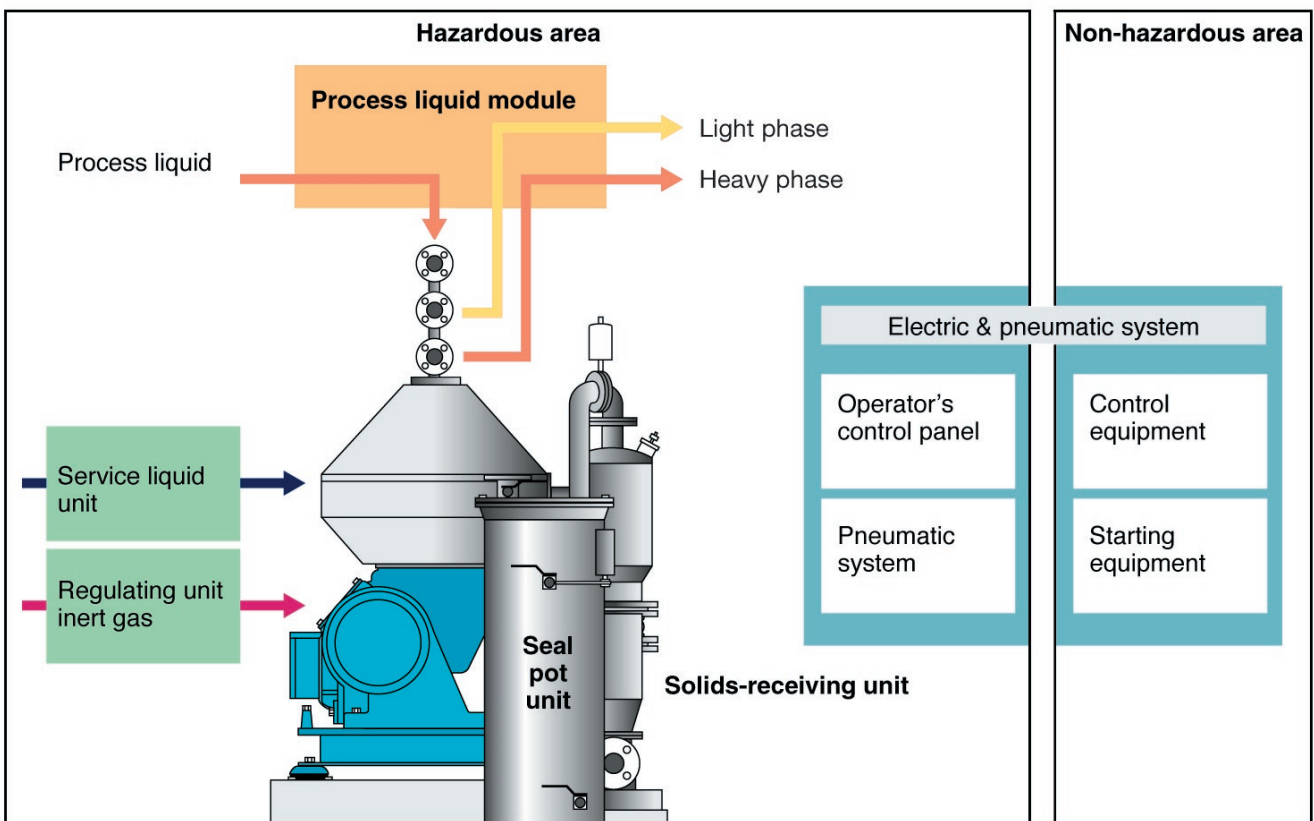

Fig. 1. Typical bowl drawing for a solids-ejecting centrifuge in clarifier execution. Drawing details do not necessarily correspond to the centrifuge described.

Schematic flow diagrams



Design principle of a steam-sterilizable and contained centrifuge installation



Design principle of an explosion-protected and inert gas purged centrifuge installation.

Technical data

Hydraulic capacity	3 m ³ /h*
G-force, max	12,800
Bowl speed	6,000-9,650 rpm
Installed motor power, control torque	7.5 kW
Main power supply	3x400x50 Hz
Noise level	77 dB(A)

* Actual capacity depends on feed material and separation demands.

Utilities consumption

Electric power, max	7.6 kW **
Operating water	0.2-0.35 l per discharge
Flushing above/under the bowl	up to 10 l per discharge

** Depends on feed flow rate.

Shipping data (approximate)

	Centrifuge	Complete system
Net weight	450 kg	1,400 kg
Gross weight	600 kg	1,760 mm
Volume	1.0 m ³	12 m ³

Main dimensions (approximate) ***

	Centrifuge	Complete system
Height	1,200 mm	2,150 mm
Width	900 mm	2,800 mm
Depth	900 mm	1,300 mm

*** Can vary according to specific demands.

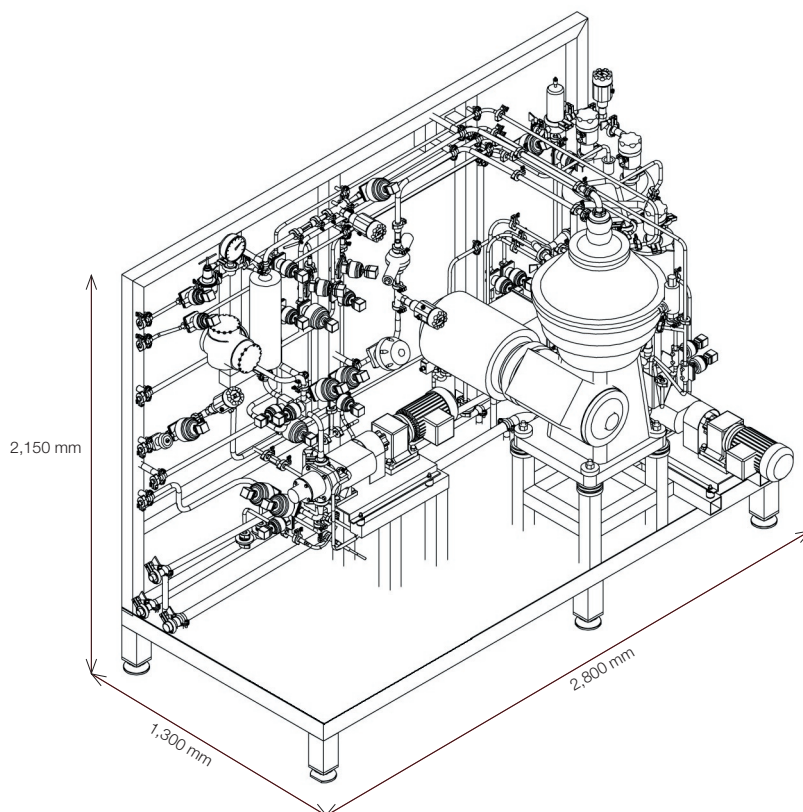
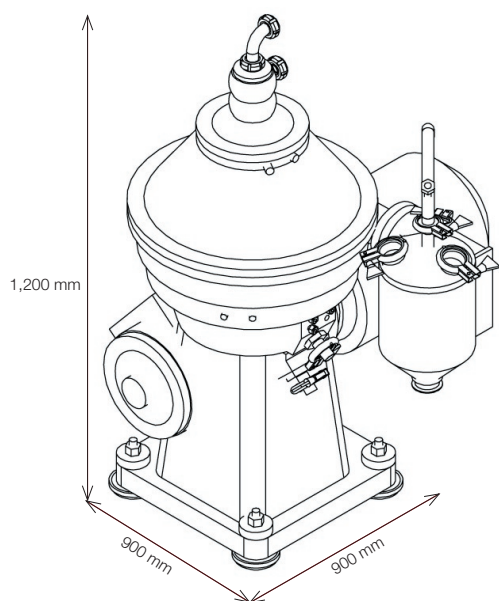

PPM00107EN 0410

Alfa Laval reserves the right to change specifications without prior notification.

How to contact Alfa Laval

Contact details for all countries are continually updated on our website. Please visit www.alfalaval.com to access the information direct.